



APPLICATION

4Y series is a modern weighing device, especially useful when the measurement requires perfect accuracy and high speed.

FEATURES OF 4Y SERIES MICROBALANCE

REPEATABILITY (SD) **<1d** MEASUREMENT DURATION **<5 s.**



UYA 2.4Y
(standard solutions for any operating conditions)



UYA 2.4Y.F
(filters weighing)



UYA 2.4Y
(control of piston pipettes volume)

ACCURACY

Measurement accuracy is guaranteed with an adjustment procedure carried out using an internal adjustment weight. This fully automatic process is controlled by a module intended to diagnose ambient conditions change (on-line). Adjustment processes (internal and external) can be performed in accordance with a specially designed schedule.

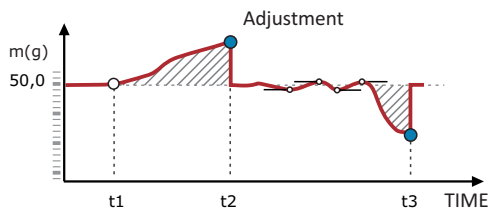

FUNCTIONALITY

4Y series microbalance is an optimized modern device which features an option of automatic level control (Level SENSING) as one of numerous functions.

The practical effect of balance customization are individual user profiles and gradable permission levels for access to balance menu.

Programmable proximity sensors offer wide range of possibilities: weighing chamber control, zeroing, tarring, printout.

Several functions such as differential weighing facilitate multi-stage mass control of one and the same sample subjected to various processes. Pipettes calibration function is an ergonomic tool designed to calibrate and control piston pipettes with the use of gravimetric method. MEDIA module, as one of the greatest 4Y series assets, provides the user with an on-screen help and support.

COMPLIANCE WITH REGULATIONS

Owing to security system and possibility to document the process by means of printouts (standard/editable), the 4Y balance meets requirements imposed by GLP/GMP systems for various industries (pharmacy, petrochemistry, environmental protection).

- PARTS COUNTING
- DOSING
- CHECKWEIGHING
- FORMULATION
- PERCENT WEIGHING [%]
- STATISTICS
- ANIMAL WEIGHING
- DIFFERENTIAL WEIGHING
- PIPETTES CALIBRATION
- SQC
- AUTOTEST
- AUTOMATIC DOOR
- AIR DENSITY CORRECTION
- GLP / GMP PROCEDURES
- INFRARED SENSORS
- AMBIENT COND. MONITORING
- UNITS

MEDIA module support within a reach of your hand

A sheer novelty of 4Y microbalance is the MEDIA module. With it you can learn using videos providing information on any relevant matter.



MEDIA module is a convenient way allowing you to broaden your knowledge on mass measurement but not exclusively (recommendations, SOP, reminders, self-designed testing procedures).

Technical specification:

	UYA 2.4Y	UYA 2.4Y.F
Verification	YES	YES
Maximum capacity	2,1 g	2,1 g
Minimum load	0,01 mg	0,01 mg
Readability	0,1 µg	0,1 µg
Repeatability at low load *	0,25 µg (Rt≤0,2g)	0,25 µg (Rt≤0,2g)
Repeatability at nominal load *	0,4 µg (0,2g<Rt≤2g)	0,4 µg (0,2g<Rt≤2g)
Linearity	±1,5 µg	±1,5 µg
Eccentricity	1,5 µg	1,5 µg
Sensitivity offset	$1,5 \times 10^{-6} \times Rt$	$1,5 \times 10^{-6} \times Rt$
Sensitivity temperature drift	$1 \times 10^{-6} / ^\circ\text{C} \times Rt$	$1 \times 10^{-6} / ^\circ\text{C} \times Rt$
Sensitivity time drift	$1 \times 10^{-6} / \text{Year} \times Rt$	$1 \times 10^{-6} / \text{Year} \times Rt$
Minimum sample weight (USP)	0,6 mg	0,6 mg
Minimum weight (U = 1%, k = 2)	0,06 mg	0,06 mg
Weighing pan	∅ 16 mm	∅ 50 mm
Weighing chamber	∅ 90 × 90 mm	∅ 118 × 35 mm
Stabilization time	10 - 20 s	
Adjustment	automatic (internal)	
Power supply	13,5 ÷ 16 V DC / 700 mA	
Terminal housing	ABS plastic	
Terminal display	colour 5,7"(640x480) with a resistive touch screen	
Processor	2 × 1 GHz	
Memory	RAM: 256 MB DDR2, flash: 8 GB microSD	
Interfaces	2×USB host, 2×RS 232, Ethernet 10/100 Mbit, Wireless Module	
Audio module	YES (voice messages support)	
Video support	YES (videos and multimedia instructions)	
Manual on screen	YES	
IN / OUT	4 in / 4 out (digital)	
Packaging size	660×660×455 mm	
Net weight/Gross weight	9,1kg / 16,6 kg	
Ambient conditions:		
Operating temperature	+10 ° ÷ +30 °C	
Operating temperature change rate	±0,3°C/1h (±1°C / 8h)	
Relative humidity	40% ÷ 80%	
Relative humidity change rate	±1%/h (±4%/8h)	

Rt - net weight

* - Non-condensing conditions

Dimensions:

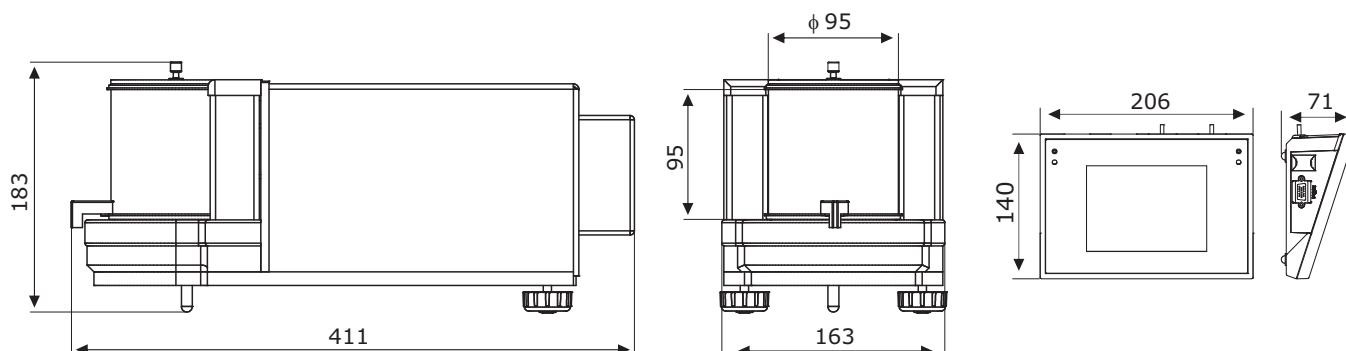

Owing to fastidious selection of mechanical design components our balance allows to obtain great stability and repeatability of indications regardless of measured sample size and conditions of use. Multi-shield mechanical design of the weighing module provides excellent thermal stability. Even with challenging ambient temperature your weighing is precise and accurate.

4Y microbalances offer modern hardware and software. In-built programs, Windows Embedded Compact 7 operating system, Flash memory, Double Hardware system guarantee fast measurement and reliability when it comes to data acquiring and processing. The 4Y series comprises 5,7" colour touchscreen providing ever more increased balance operation functionality and even more practical results presentation. Complex databases allow measurement record along with printout and export option.

Dimensions:

F version

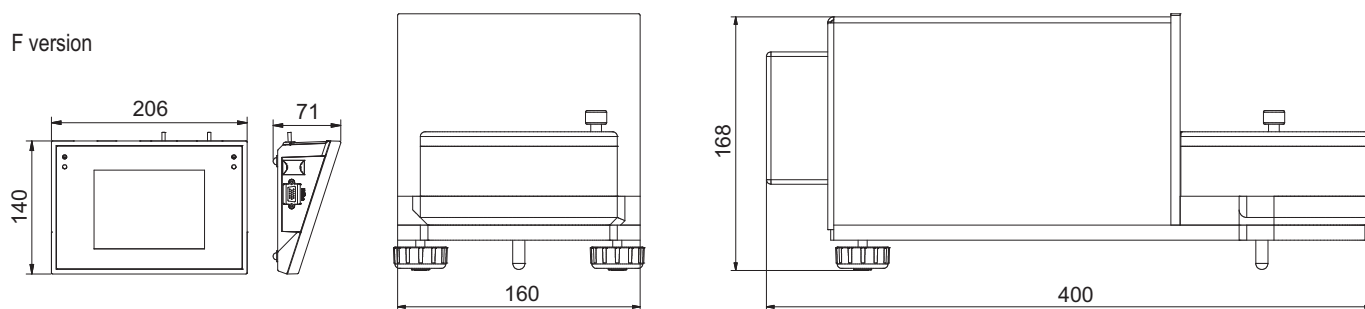

Additional equipment:

Anti vibration table for microbalance	Ambient conditions module
Professional weighing table	Additional LCD display "WD-5"
Impact Epson printer	PC keyboard
Label printer Citizen	Power adapter with battery and charger ZR-02
Anti draft shield for microbalances	Mass standard
"Tare" and "Print" foot button	Antistatic cable
"R-LAB" computer software	Bar code scanner
"REC-FS" computer software	Cable RS 232 (balance - computer) "P0108"
Antistatic ionizer DJ-03	Cable RS 232 (balance - Epson, Citizen printer) "P0151"