



TEROS-10 SOIL MOISTURE SENSOR

What is soil moisture?

Soil moisture is a key variable in controlling the exchange of water and heat energy between the land surface and the atmosphere through evaporation and plant transpiration.



Preparation:

Inspect and verify Teros-10 components. The Teros verification clip gives the best assessment of proper sensor function and accuracy. The Teros-10 should read 0.35 to 0.42 m³/m³ on the verification clip. If a verification clip is not available, test basic sensor functionality in air and water. The Teros-10 will read ~0.64 m³/m³ in water and a slightly negative value in air.

Note: The sensors are optimized to read in soils, therefore the sensor will not read 100% in pure liquid water. Values above use the mineral soil calibration.

Installation Tool:

Proper installation of the sensors is critical for proper operation. Refer to the Teros-10 User Manual for details. For easy installation, use the borehole installation tool. The installation tool (shown below) is available for rent from us.

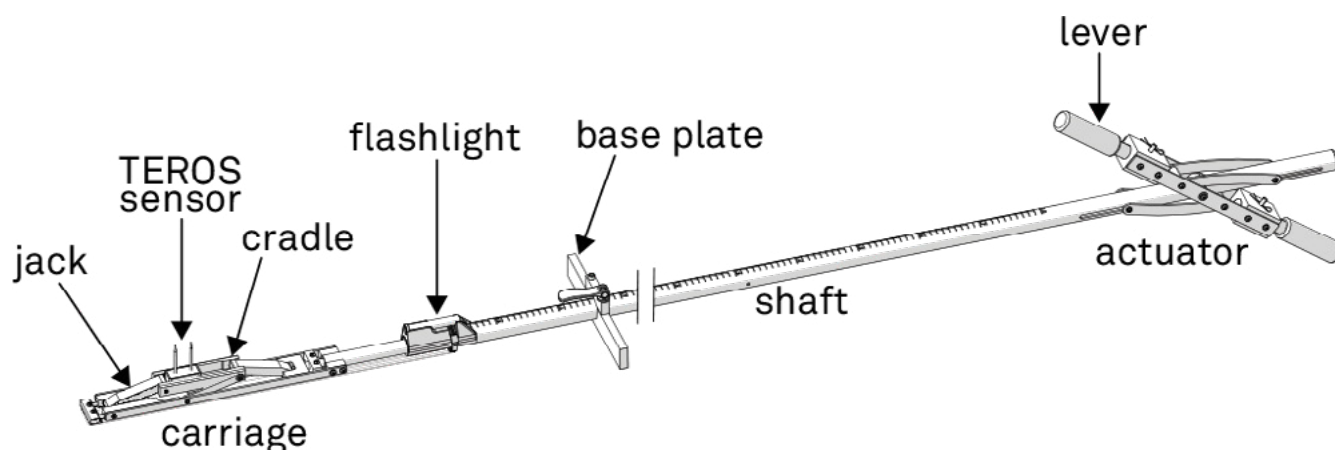

TEROS-10

Installation:

1. Insert Sensor - Auger or trench a hole to the desired sensor depth. Insert the sensor into the undisturbed soil. When using the borehole installation tool, load the TEROS-10 as shown. Lower the tool into the hole or trench with the back of the tool supported by the far wall. Pull on the lever to activate the jack and insert the sensor into hole wall.

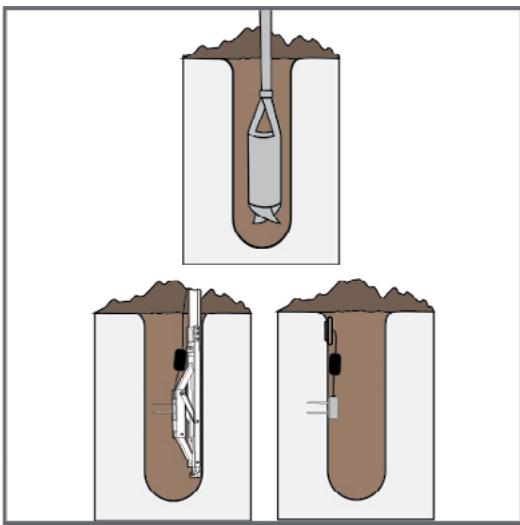

3. Repack Soil and Protect Cables - Secure and protect cables with PVC casing or flexible conduit and backfill the trench or hole.

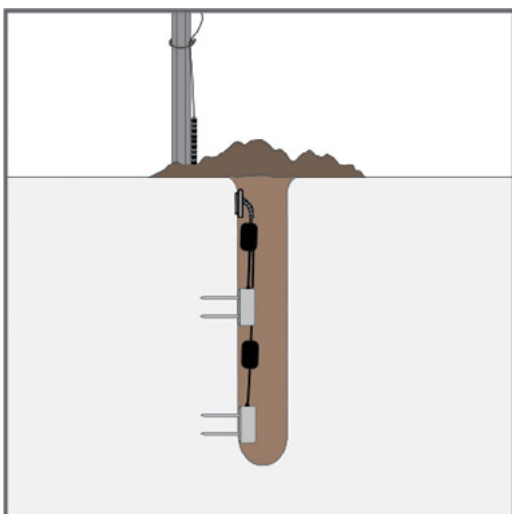

2. Check Sensor Operation - Plug the sensor into the data logger and use the SCAN function in the software to do a quick check of sensor operation before backfilling.

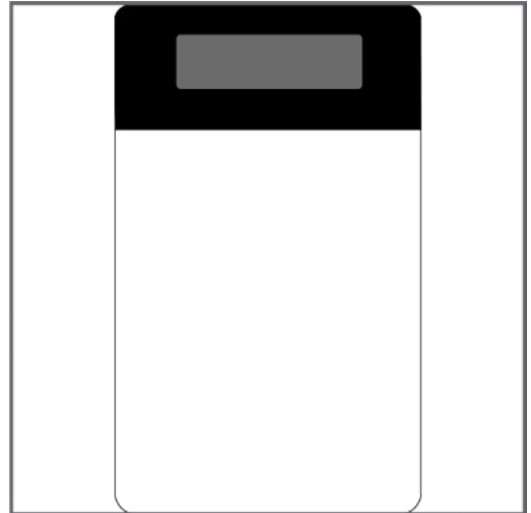

4. Plug Sensor In and Configure Logger - Plug the sensor into the data logger. Use data logger software to apply appropriate settings to the sensors plugged into each data logger port.

The TEROS-10 is an analog sensor and will not be automatically recognized on our data loggers. Select the right sensor for each port.

